

# 1994+ K1100LT Wiring

1. Fuses
2. Power, Ground, Fuse
3. Instrument Cluster
4. Motronic – Inputs
5. Motronic – Outputs
6. Starter, Alternator
7. ABS
8. Lights, Brake Lights
9. Flashers, Horn
10. Windscreen
11. Radio
12. Reading Light
13. Heated Grips, Extras
14. Component List

## Fuses - 1994 on K1100LT

	Source	Outputs
Fuse 1	Motronic Relay(87)	Front Brake Switch Rear Brake Switch BMU (2) Fuel/Temp Gauges Heated Grips
Fuse 2	Ignition Switch	Parking Light Tail Light via BMU (5->6)
Fuse 3	Battery (Unswitched)	Flasher Relay (11) Clock
Fuse 4	Battery (Unswitched)	Optional Equipment Connectors
Fuse 5	Battery (Unswitched)	Motronic(15) Motronic Relay(30)
Fuse 6	Battery (Unswitched)	Fuel Pump Relay(30)
Fuse 7	Load Shed Relay	Fan Relay(15) Horn Relay (15) Flasher Relay (13) Windscreen Up/Down Switch Optional Equipment Connectors
Fuse 8	From Ignition Switch	Map Light Radio
Fuse 9	Battery (Unswitched)	Radio Windscreen Relays to Motor
Fuse 10	Empty	

# Plus, ground distribution, fuses

## 1994 on K1100LT

# 2

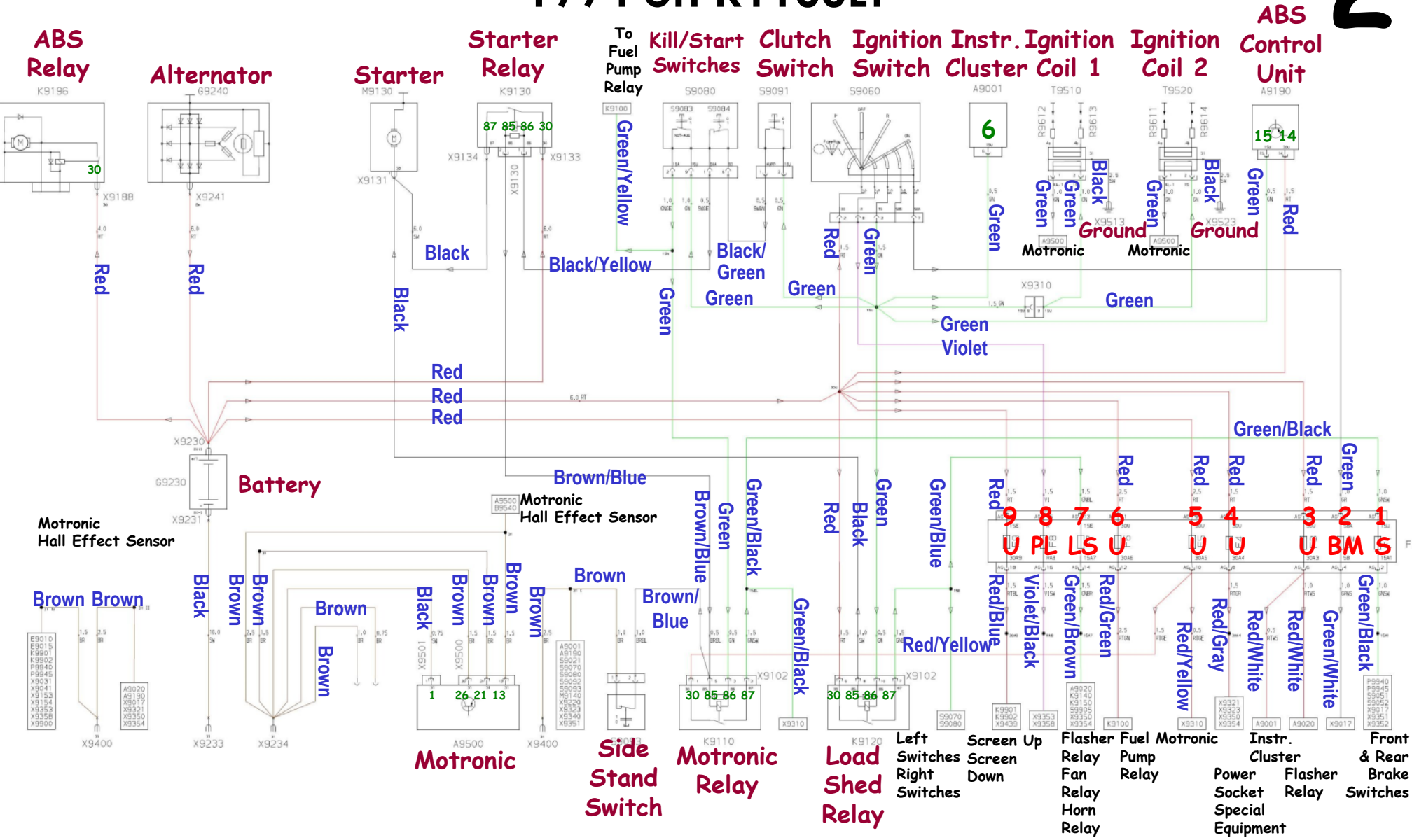

# Instrument Cluster 1994 on K1100LT

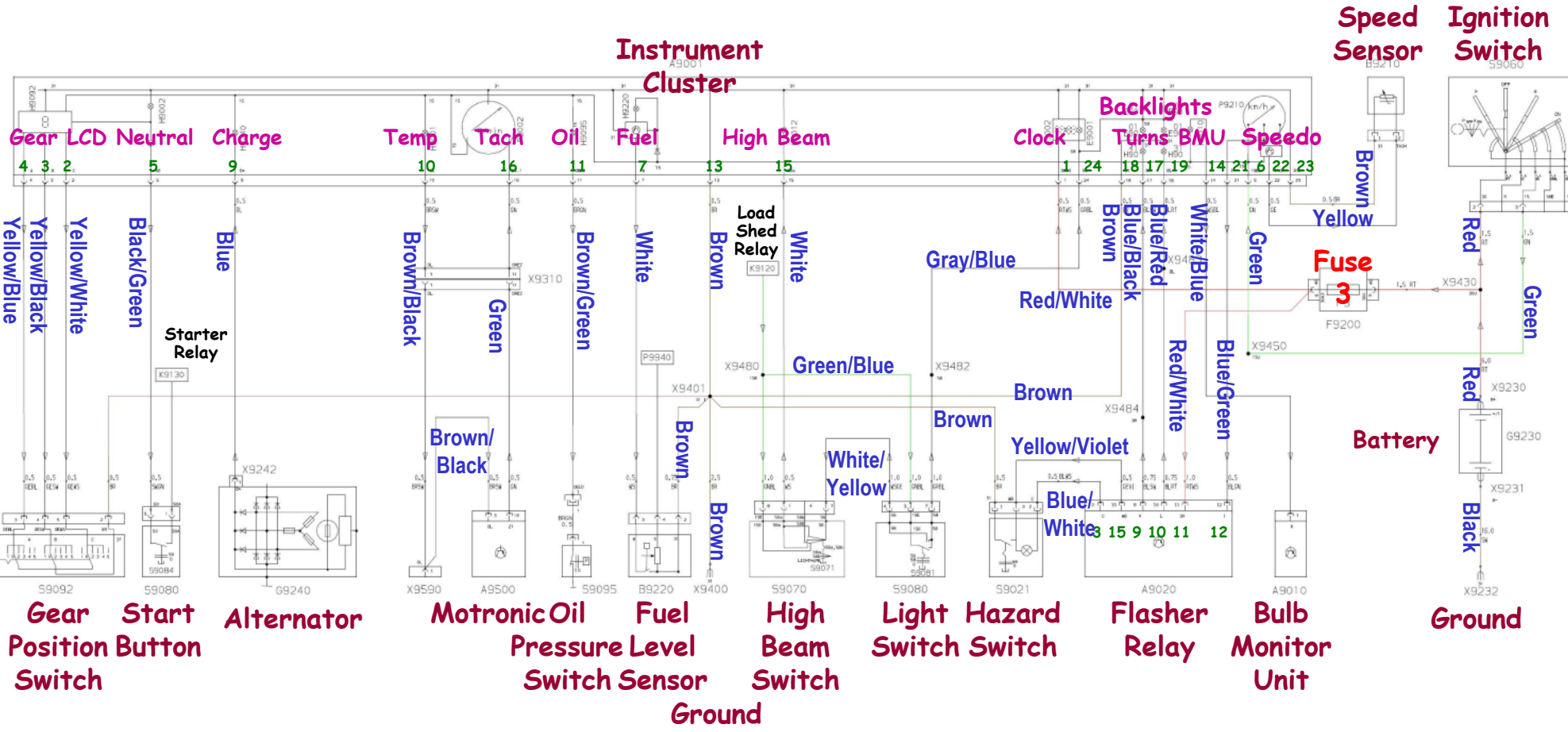

# Motronic with Inputs - US 1994 on K1100LT

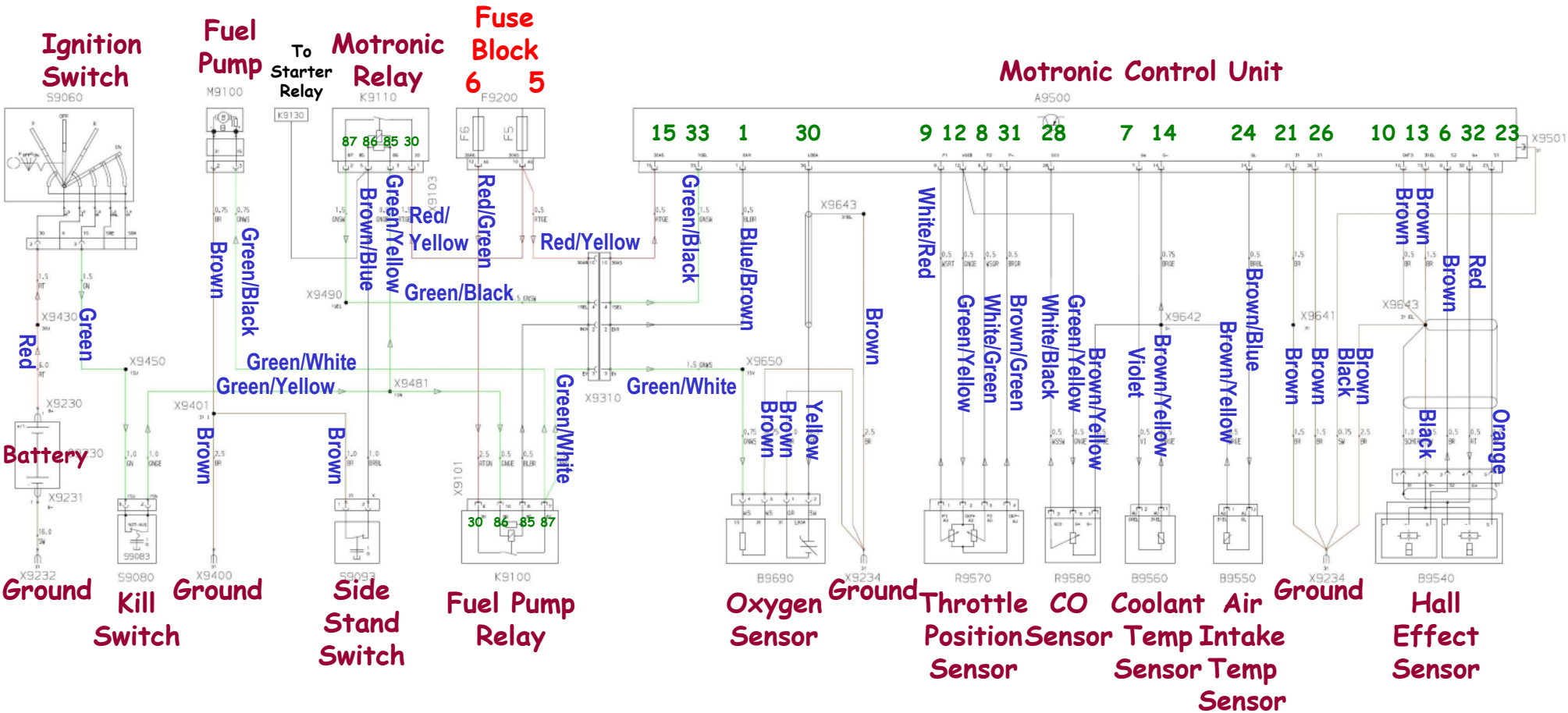

## Motronic with Outputs 1994 on K1100LT

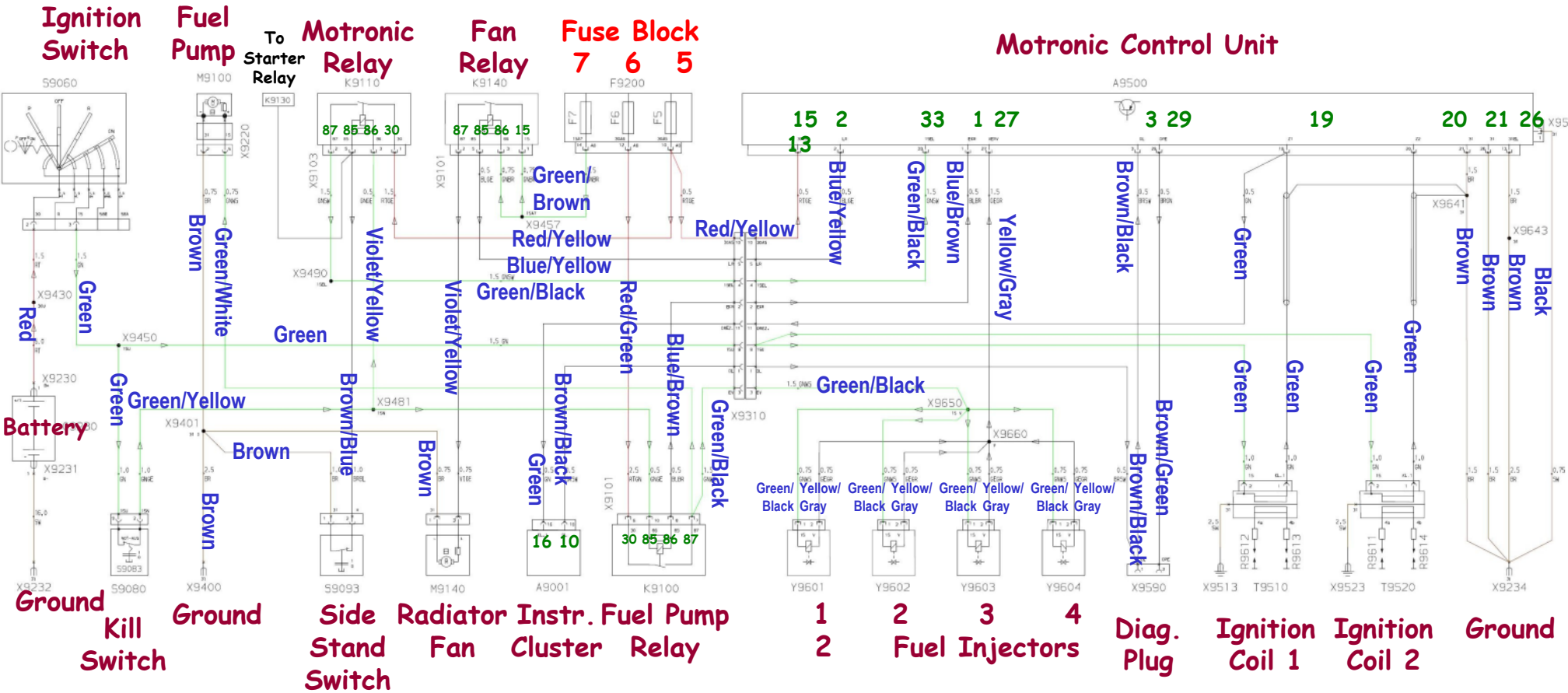

## Starter/Alternator 1994 on K1100LT

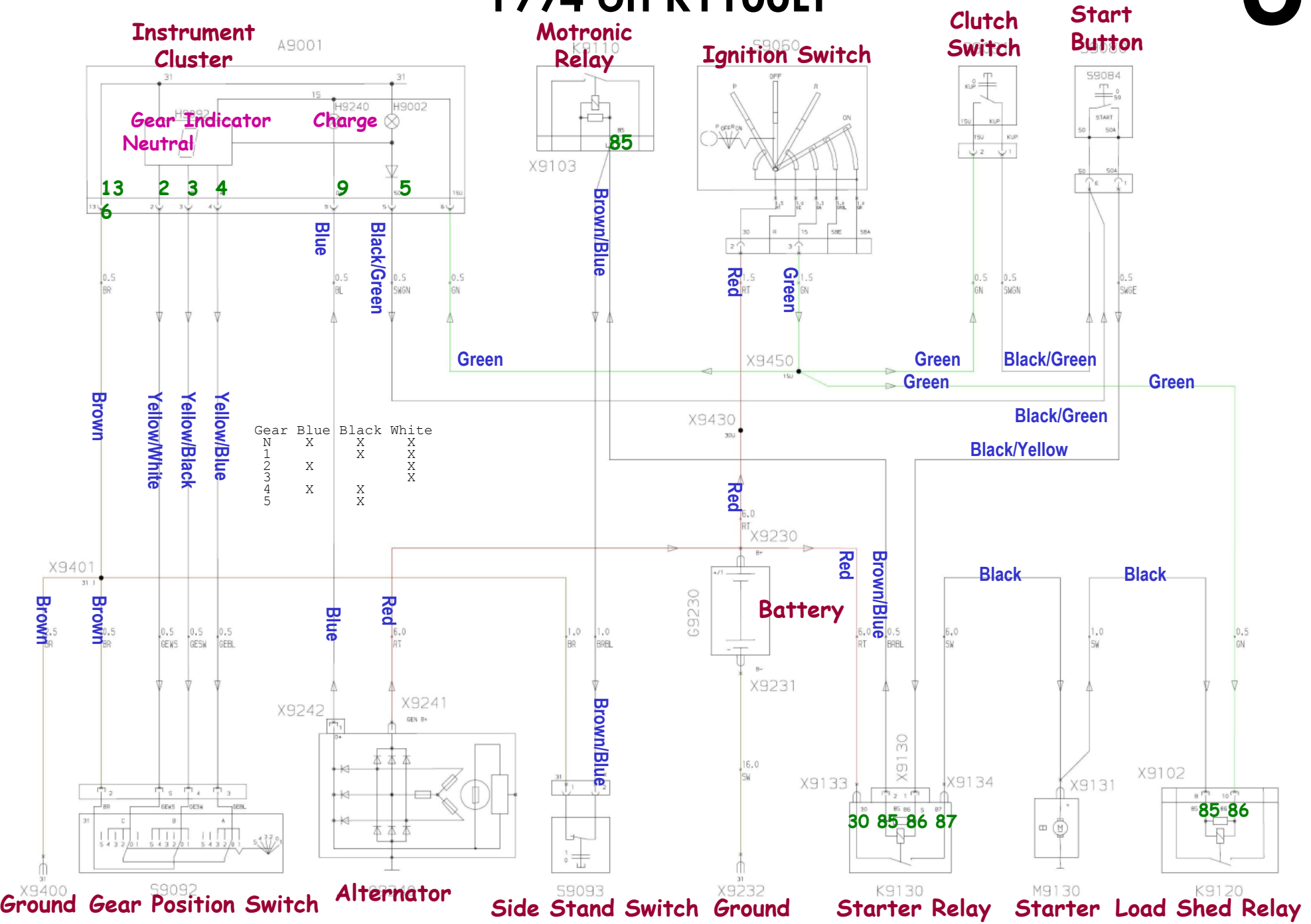

# ABS 1994 on K1100LT

## Ignition Switch

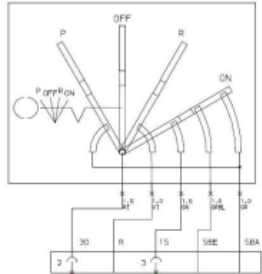

## ABS Control Unit A9190

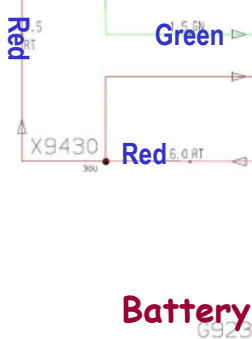

## Battery

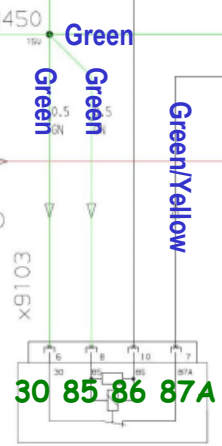

## ABS Warning Relay



## Instrument Cluster

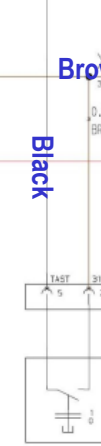

## ABS Switch



## Ground

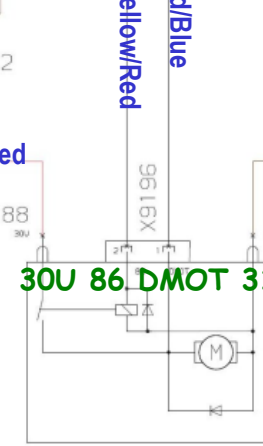

## ABS Relay



## Ground



## Rear ABS Sensor



## Front ABS Sensor

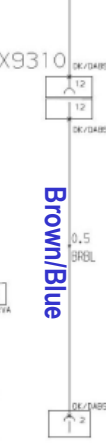

## Diag. Plug





## Indicator with Horn 1994 on K1100LT

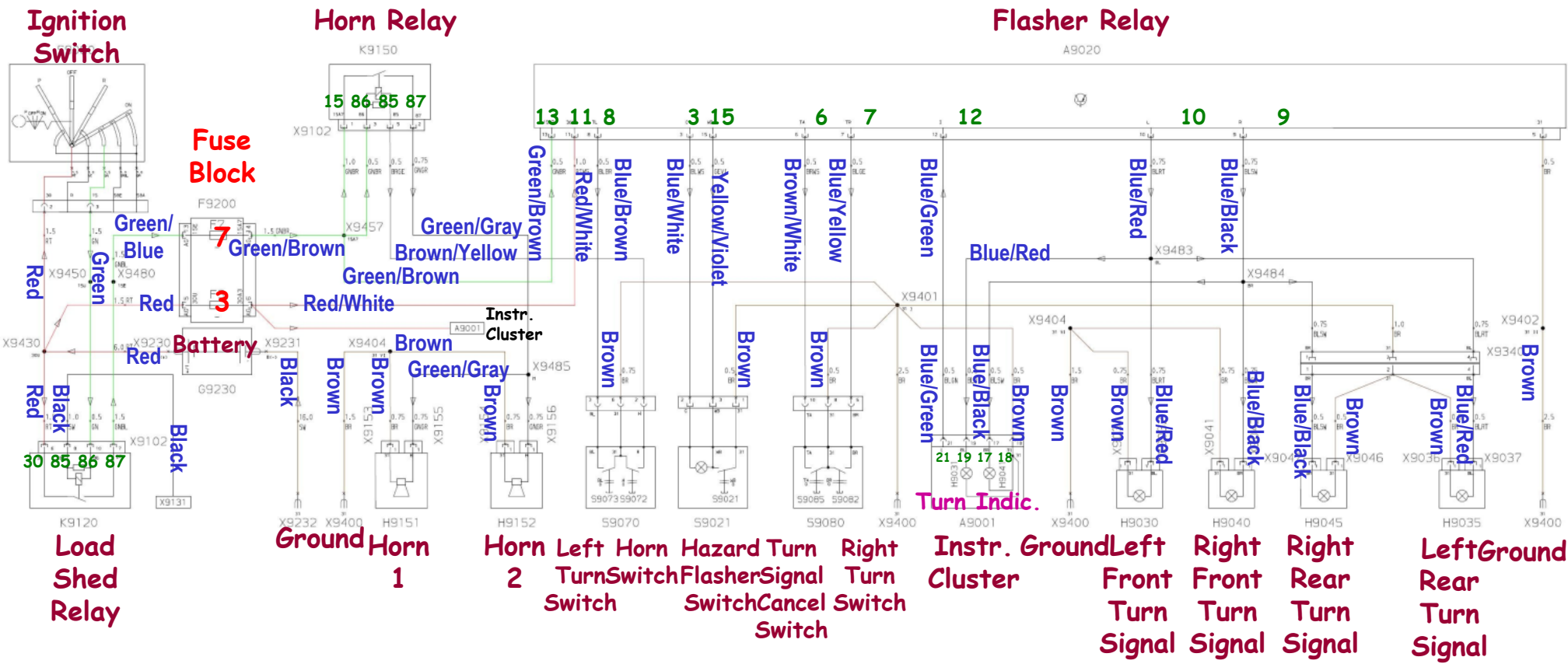



# Radio 1994 on K1100LT

# 11

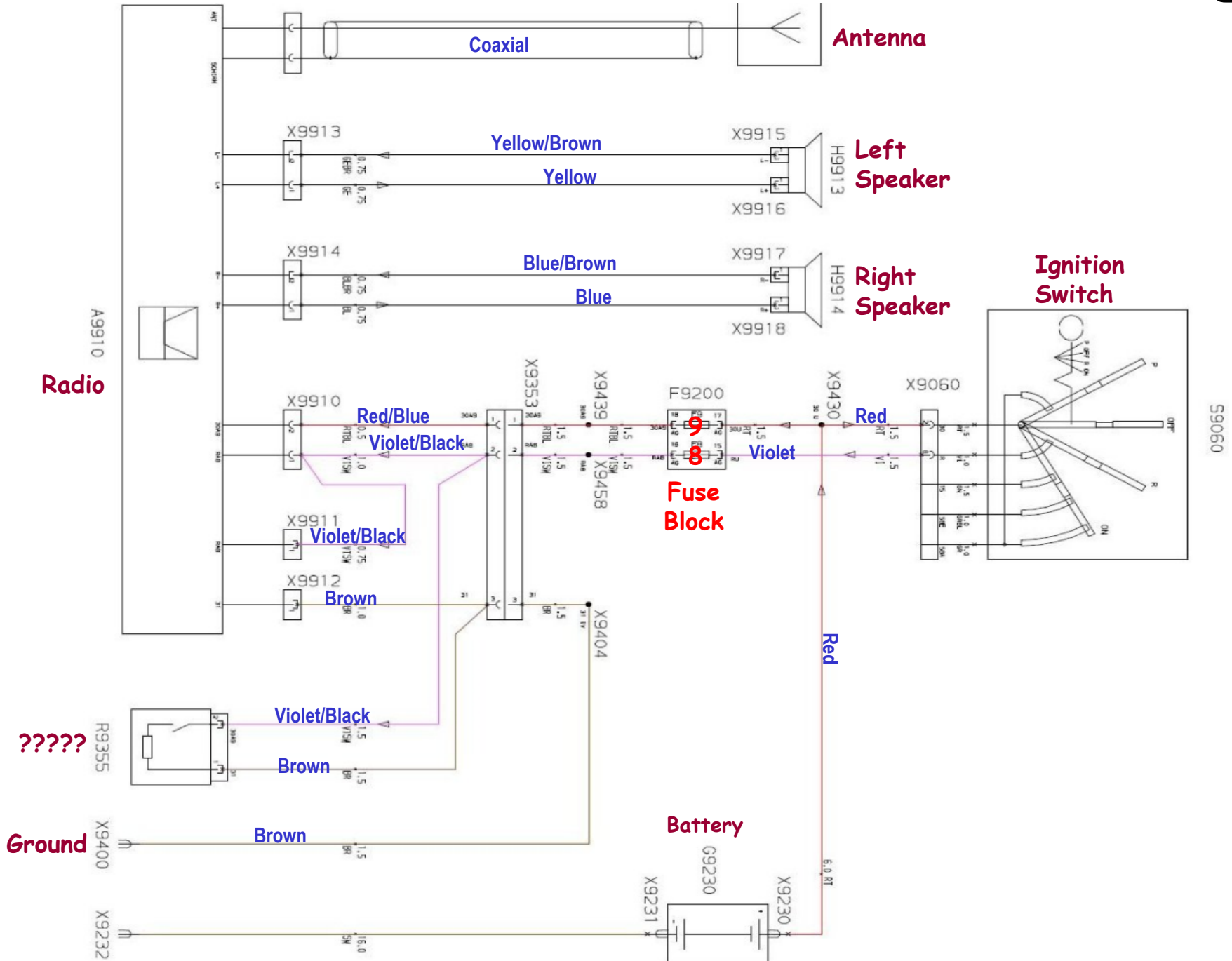



# Heated Grips - Power Socket - Extra - Alarm

# 13

Heated Grip Switch  
S9930

Ignition Fuel Switch Gauge  
P9940

## 1994 on K1100LT

Temp. Gauge  
P9945

Temp. Sensor  
B9562

Horn 2  
H9152

Horn 1  
H9151

Fuse Block  
F9200

Fuse 1  
F9200

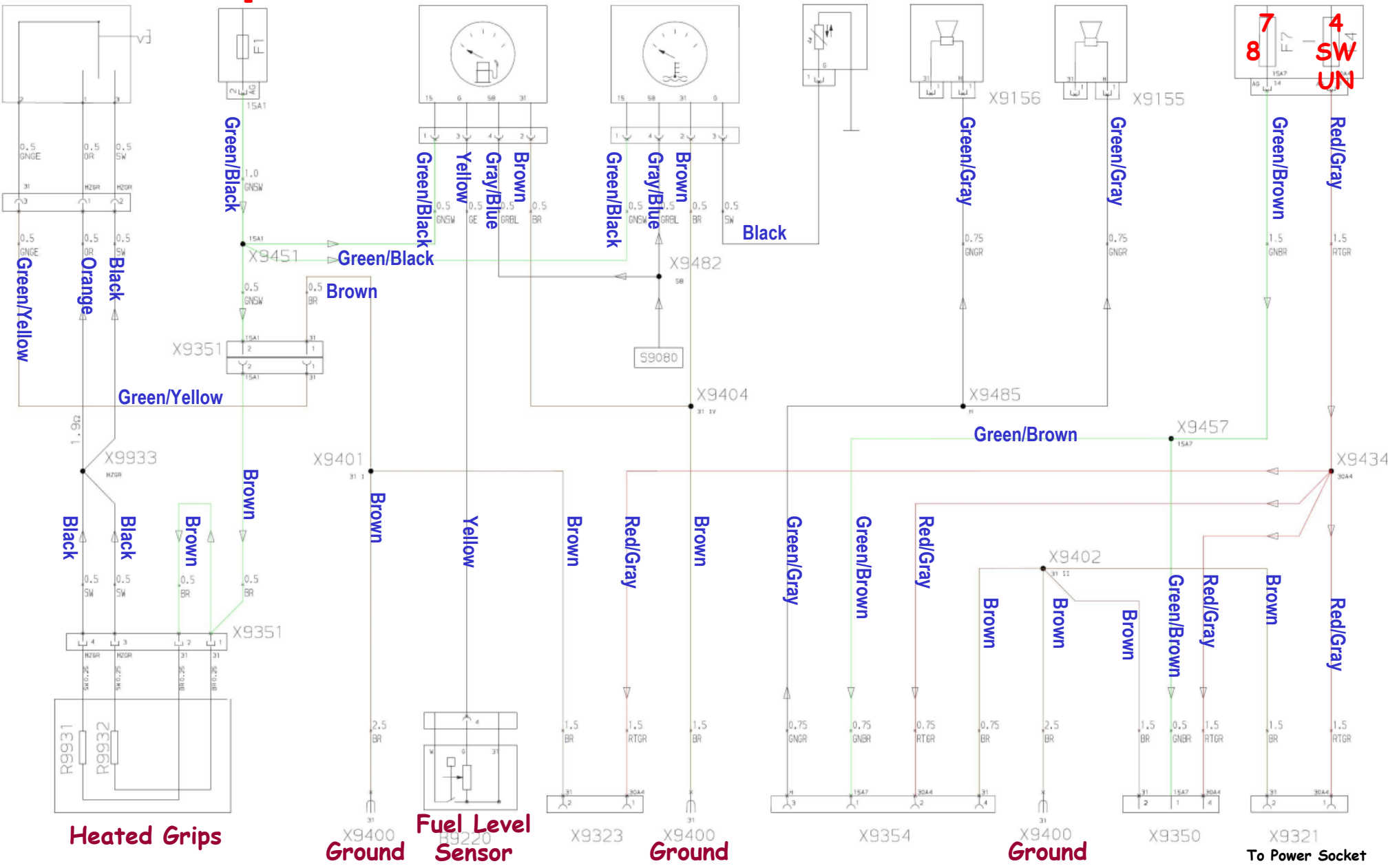

Heated Grips

Ground

Fuel Level Sensor

Ground

Ground

To Power Socket

Components - 1994+ K1100LT

A9001 Instrument panel control unit	K9110 Engine-electronics relay	T9510 Ignition coil 1	X9357 STVB map light +
A9020 Flasher unit	K9120 Load relief relay	T9520 Ignition coil 2	X9358 STVB map light
A9190 ABS control unit	K9130 Starter relay	X9013 rear light -	X9400 Ground I
A9500 Control unit, engine electronics	K9140 Fan relay	X9014 tail light	X9401 Connector 31 I
A9910 Radio	K9150 Horn relay	X9015 parking light	X9402 Connector 31 II
B9193 Front ABS sensor	K9196 ABS relay	X9016 parking light	X9404 Connector 31 IV
B9194 Rear ABS sensor	K9197 ABS warning relay	X9031 front left turn signal -	X9430 Connector 30U
B9210 Vehicle speed sensor	K9901 Relay, raise windscreen	X9032 front left turn signal +	X9434 Connector 30A4
B9220 Fuel level sensor	K9902 Relay, lower windscreen	X9036 rear left turn signal -	X9439 Connector 30A19
B9540 Hall sensor	M9100 Fuel pump	X9037 rear left turn signal +	X9450 Connector 15U
B9550 Temperature sensor, air intake	M9130 Starter	X9041 front right turn signal -	X9451 Connector 15A6
B9560 Coolant temperature sensor	M9140 Fan	X9042 front right turn signal +	X9457 Connector 15A7
B9562 Temperature sensor, coolant	M9900 Motor for windscreen adjustment	X9046 rear right turn signal -	X9458 Connector RA8
B9690 Oxygen sensor	P9002 Revolution counter	X9047 rear right turn signal +	X9465 Connector MUTE
E9001 Instrument lights	P9210 Speedometer	X9053 brake light -	X9480 Connector 15E
E9010 Headlight	P9210 Speedometer	X9054 brake light +	X9481 Connector 15N
E9011 Low beam headlight	R9570 Throttle potentiometer (DKP)	X9060 Ignition switch	X9482 Connector 58
E9012 High beam headlight	R9580 CO-potentiometer	X9080 right multi-switch	X9483 Connector BL
E9013 Tail light	R9611 Spark plug 1	X9101 Eng. elec/fuel pump relay	X9484 Connector BR
E9015 Side light	R9612 Spark plug 2	X9102 Horn/load relief relay	X9485 Connector horn
E9358 Map light	R9613 Spark plug 3	X9130 starter relay	X9490 Connector 15EL
F9200 Fuse box I	R9614 Spark plug 4	X9131 starter	X9500 STVB control unit, engine electronics
G9230 Battery	R9931 Left heated handlebar grip	X9133 starter relay	X9501 STVB control unit ground, engine electronics
G9240 Alternator	R9932 Right heated handlebar grip	X9134 starter relay	X9513 Ignition coil ground
H9001 Warning light, coolant temperature	S9021 Hazard warning switch	X9140 fan	X9590 Diagnosis plug
H9002 Telltale light, neutral	S9051 Brake light switch, hand	X9155 horn I	X9642 Connector, ground sensor
H9010 Lamp indicator lamp	S9052 Brake light switch, foot	X9156 horn II	X9643 Connector, shield
H9012 Telltale light, high-beam	S9060 Ignition switch	X9188 ABS relay	X9650 Connector 15V
H9030 Front left turn signal	S9070 Left multi-function switch	X9189 ABS relay	X9660 Connector V
H9031 Left turn signal repeater	S9071 High beam switch	X9196 ABS relay	X9900 STVB windscreen adjustment
H9035 Rear left turn signal	S9072 Horn switch	X9220 fuel level	X9901 DRS disc relay
H9040 Front right turn signal	S9073 Left turn signal switch	X9230 Battery positive	X9910 STVB radio
H9041 Right turn signal repeater	S9080 Right multi-function switch	X9231 Battery ground	X9911 STVB radio
H9045 Rear right turn signal	S9081 Light switch	X9232 Ground	X9912 STVB radio
H9050 Brake light	S9082 Right turn signal switch	X9233 Gearbox ground	X9913 STVB speaker, left
H9092 Gear indicator	S9083 Emergency stop switch	X9241 alternator +	X9914 STVB speaker, right
H9095 Warning light, oil pressure	S9084 Starter switch	X9242 alternator D+	X9915 STVB speaker, left -
H9151 Horn I	S9085 Turn indicator cancel switch	X9321 on-board socket 1	X9916 STVB speaker, left +
H9152 Horn II	S9091 Clutch switch	X9340 lighting/rear direction	X9917 STVB speaker, right -
H9190 Warning light, ABS	S9092 RFH switch	X9349 optional accessory	X9918 STVB speaker, right +
H9220 Fuel warning lamp	S9093 Side-stand switch	X9350 optional extra	X9933 Connector heated handlebar grips
H9240 Warning light, battery charge	S9095 Oil pressure switch	X9351 heated handlebar grips	Y9601 Injection valve 1
H9913 Speaker left	S9195 ABS button	X9353 radio II	Y9602 Injection valve 2
H9914 Speaker right	S9901 Position switch up	X9354 DWA	Y9603 Injection valve 3
K9100 Fuel pump relay	S9902 Position switch down	X9356 map light -	Y9604 Injection valve 4
	S9930 Switch for heated handlebar grips		